

# AF120 Mk2

## Mobile Foam Unit

- Self-contained mobile foam unit
- Rapid deployment of foam extinguishing agent
- Improved handling and mobility
- Low maintenance



The innovatively designed **Angus HI-COMBAT AF120 MK2** is a fully self-contained mobile foam unit which has been specifically developed for the rapid deployment of foam extinguishing agent to fires and chemical spills. Further refinement has been achieved through a detailed ergonomic review and lower centre of gravity design, resulting in improved handling and mobility.

Requiring only connection to a suitable water supply, the standard unit comprises a 120 litre foam concentrate tank, **HI-COMBAT UNI-225** inductor and **F225/HU** low expansion foam branchpipe. Also two 15m lengths of dutch coiled 45mm diameter Duraline fire hose, fitted with light alloy 21/2" instantaneous couplings to BS336 (other connections available to special order). A shut off ball valve is also fitted to the inductor as standard, to facilitate swift operation by just one person.

This improved performance combined with an effective fire fighting capability makes the **Angus HI-COMBAT AF120 Mk2** ideal for the protection of smaller flammable liquid hazards such as boiler rooms, oil storage and loading terminals, paint or spirit stores, airfields, industrial sites, generator rooms and similar high risk areas. The **HI-COMBAT AF120 Mk2** provides a compact and highly efficient fire fighting unit, on hand for a fast response with minimum manpower requirements.

This highly versatile unit is suitable for use with any type of foam concentrate, but is particularly effective when used with **Angus Alcoseal** and **Petroseal** Film Forming FluoroProtein foams. When used with **Alcoseal 3-3** it effectively becomes an AF240, doubling the operating time on Polar Solvent fires.

The ability to use **Angus HI-COMBAT MEX225U** and **MEX450U** medium expansion foam branchpipes with this unit, makes it particularly suitable for rapid intervention in cases where vapour suppression of chemical spills is a necessity.

All component parts and materials have been chosen to minimise maintenance requirements. The foam tank is constructed from high strength, chemical-resistant GRP resin and is mounted on a corrosion resistant, thermoplastic coated steel chassis. A footbrake is also provided for maximum stability on a slope.

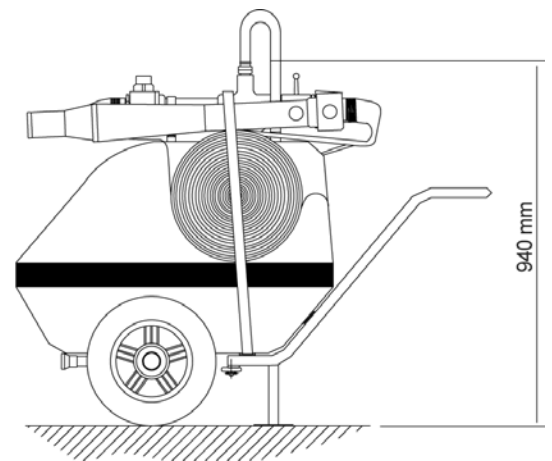
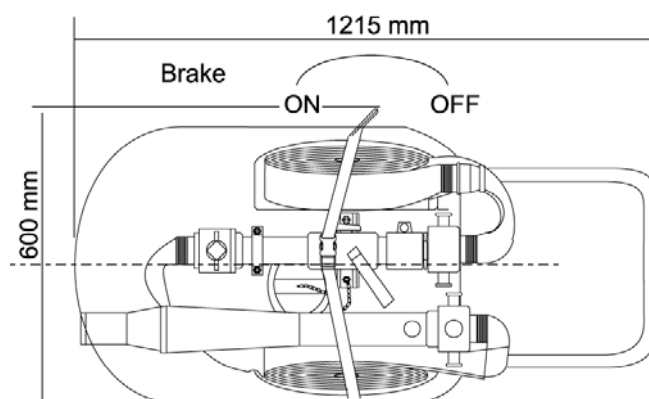

# AF120 Mk2

## Mobile Foam Unit

### Alternative Versions

The following alternative options to the standard version of the AF120 Mk2 may be specified:

Inductor Options	Branchpipe Options
HI-COMBAT UNI-225 Inductor	HI-COMBAT B225
	HI-COMBAT MEX225U
HI-COMBAT UNI-450 Inductor	HI-COMBAT F450/HU
	HI-COMBAT MEX450U

For more information on these delivery devices see separate datasheets.

### Operating Time

Using Angus Fluoroprotein (FP70/FP70 Plus), FFFP (Petroseal & Alco seal), or AFFF (Tridol) concentrates and HI-COMBAT F225/HU branchpipes at 3% induction rates, the HI-COMBAT AF120 Mk2 provides a typical operating time of 16 - 22 minutes, dependent on operating pressure.

Construction		
Foam Tank		Chemically resistant, UV stabilised GRP resin
Chassis		Thermoplastic coated steel
Tyres		Solid rubber
HI-COMBAT Inductor	UNI-225, UNI-450	Light alloy
HI-COMBAT branchpipe	F225/HU, F450HU	Light alloy
	B225	Stainless steel
	MEX 225U, MEX 450U	Stainless steel

Typical Packing Specification	
Container	One case (plywood)
Approx case dimensions	1020mm x 920mm x 850mm
Dimensions of the AF120 Mk2 (assembled)	1215mm x 600mm x 940mm
AF120 Mk2 approx. nett weight (empty)	65 Kg

#### INTERNATIONAL SALES

##### Angus Fire Ltd

Angus House, Haddenham Business Park,  
Pegasus Way, Haddenham, Aylesbury, HP17 8LB, UK  
Tel: +44 (0)1844 293600 • Fax: +44 (0)1844 293664

#### UK SALES

##### Angus Fire Ltd

Station Road, Bentham, Lancaster, LA2 7NA, UK  
Tel: +44 (0)1524 264000 • Fax: +44 (0)1524 264180

Angus Fire operates a continuous programme of product development. The right is therefore reserved to modify any specification without prior notice and Angus Fire should be contacted to ensure that the current issues of all technical data sheets are used.

© Angus Fire  
5047/5 01.14